

Cellular LTE910XF v8.00 Plug-In XF Footprint Modem User Manual



TABLE OF CONTENTS

TABLE OF CONTENTS and DISCLAIMER.....	2
1. INTRODUCTION	3
1.1 Ordering Part Numbers	
1.2 Additional Resources	
1.3 Product Overview	
1.4 Block Diagram	
2. TECHNICAL SPECIFICATIONS.....	4-5
2.1 Electrical Specifications	
2.2 Mechanical Specifications	
2.3 Environmental Specifications	
3. IMPORTANT DESIGN CONSIDERATIONS.....	6
3.1 ON_OFF Signal	
3.2 Power Supply Requirements	
3.3 Serial Communications	
3.3 Network Connection Status LED	
4. MOUNTING GUIDELINES	7-8
4.1 Board to Board Connectors Approach	
4.2 Solder to Board Connection Approach	
5. ANTENNA CONSIDERATIONS.....	9
5.1 Antenna Requirements	
5.2 Recommended Antennas	
6. CERTIFICATIONS	9
6.1 Carrier Specific	
6.2 Geography Specific	
7. FEDERAL REGULATORY LICENSING.....	9
7.1 ECCN Number	
7.2 HTS Codes	
8. END PRODUCT LABELING REQUIREMENTS	9
ORDERING INFORMATION.....	10
REVISION HISTORY	10

DISCLAIMER

The information contained in this document is the proprietary information of Connor-Winfield Corporation and its affiliates (Janus Remote Communication). The contents are confidential and any disclosure to persons other than the officers, employees, agents or subcontractors of the owner or licensee of this document, without the prior written consent of Connor-Winfield, is strictly prohibited. Connor-Winfield makes every effort to ensure the quality of the information it makes available. Notwithstanding the foregoing, Connor-Winfield does not make any warranty as to the information contained herein, and does not accept any liability for any injury, loss or damage of any kind incurred by use of or reliance upon the information. Connor-Winfield disclaims any and all responsibility for the application of the devices characterized in this document, and notes that the application of the device must comply with the safety standards of the applicable country, and where applicable, with the relevant wiring rules. Connor-Winfield reserves the right to make modifications, additions and deletions to this document due to typographical errors, inaccurate information, or improvements to programs and/or equipment at any time and without notice. Such changes will, nevertheless be incorporated into new editions of this application note.

All rights reserved 2014 Connor-Winfield Corporation

1. INTRODUCTION

1.1 Ordering Part numbers

Ordering Information	Description
LTE910XF v8.00	LTE CAT 4 Plug-In Modem

1.2 Additional Resources

The following documents or documentation resources are referenced within this document.

Telit's LE910 V2 Hardware User Guide

1.3 LTE910XF Product Overview

Add robust cellular connectivity to your IoT devices with scalable radio technology with the standard industry 20-pin connector footprint line of modems including LE910 based LTE solutions. Extensive experience in designing and building embedded product solutions makes the LTE910XF v8.00 embedded cellular modem the smallest on the market. It supports multiple LTE bands and fallback capability minimizing costs of hardware and network access. The module is designed for volume production and is intended for OEMs to embed into end equipment designs.

1.4 Block Diagram

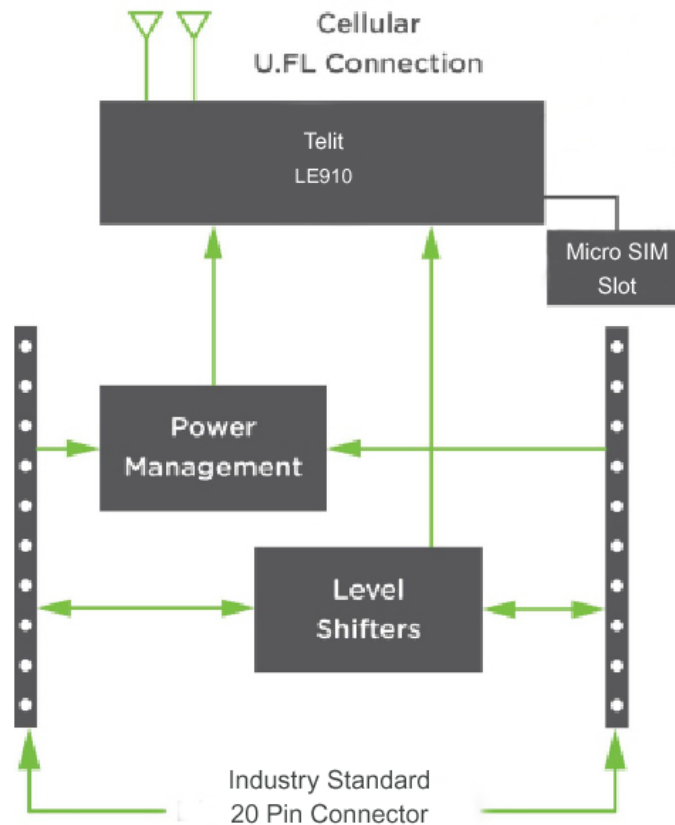

2. TECHNICAL SPECIFICATIONS

2.1 Electrical Specifications

2.1.1 Absolute Maximum Ratings

Parameter	Signal	Signal	Maximum Rating
Main Power Supply		VCC	4.3V
I/O Voltage Reference		VREF	5.0V

2.1.2 Recommended Ratings & Module Pin out

2.1.2.1 Connectors J1 and J2

Pin	Name	Direction	Description	Min	Typical	Max	If not used
1	VCC	Input	Main Power supply	3.5V	3.9V	4.3V	Must be implemented
2	DOUT	Output	UART data out, I/O level tied to VREF	VOL: GND to 0.55V		VOH: VREF x 0.67 to VREF	Must be implemented if USB not used, No connection
3	DIN	Input	UART data in, I/O level tied to VREF	VIL: GND to 0.15V		VIH: VREF-0.4 V to VREF	Must be implemented if USB not used, No connection
4	GND	Input	Ground Pin		0		Must be implemented
5	RESET_nIN	Input	Controls HW_SHUTDOWN input on Telit LE910, tie low for 200mS and released to activate. Internally pulled up to VCC. Drive with open collector output. Assert only in an emergency as the module will not gracefully exit the cellular network when asserted.		VREF		No Connection
6	VUSB	Input	Supply for USB interface	4.4V	5V	5V	No connection
7	USB_D+	I/O	USB differential Data + signal				No connection
8	USB_D-	I/O	USB differential Data - Signal				No connection
9	DTR	Input	Modem Data Terminal Ready input	VIL: GND to 0.15V		VIH: VREF-0.4 V to VREF	Tie to GND
10	GND	Input	Ground Pin		0		Must be implemented
11	GND	Input	Ground Pin		0		Must be implemented
12	CTS	Output	Modem Clear to Send hardware flow control output	VOL: GND to 0.55V		VOH: VREF x 0.67 to VREF	No Connection
13	ON/nSLEEP	Output	Signal drives the onboard LED indicating network status. OFF = Device OFF, Fast blink = Searching for Network & Not Registered, Slow Blink = Registered with full service, Permanently on = call is active. See Telit LE910 V2 manual for additional information.	0		1.8V	No Connection
14	VREF	Input	Voltage reference for offboard I/O signals. This signal drives the input voltage side of an onboard buffer which converts all external I/O voltage from VREF range to 1.8V range to drive the onboard Telit LE910 modem module.	1.65	1.8V or 3.3V	5.0V	Must be Implemented
15	GND	Input	Ground Pin		0		Must be implemented

2. TECHNICAL SPECIFICATIONS continued

2.1 Electrical Specifications

2.1.2 Recommended Ratings & Module Pin out

2.1.2.1 Connectors J1 and J2 continued....

Pin	Name	Direction	Description	Min	Typical	Max	If not used
16	RTS	Input	Modem Request to Send hardware flow control input	VIL: GND to 0.15V		VIH: VREF-0.4 V to VREF	Tie to GND
17	DIO3	I/O	Programmable GPIO_03 on Telit LE910 module	0		1.8V	No connection
18	DIO2	I/O	Programmable GPIO_02 on Telit LE910 module	0		1.8V	No connection
19	ADC1	Input	ADC_IN1 input on Telit LE910 module (10bit resolution, <1.2mV)	0		1.2V	No connection
20	ON_OFF	Input	Modem On/Off signal. Assert low for at least 5 seconds and then release to activate start sequence. Drive with open collector output. Internally pulled up to internal I/O rail with pull up. Do not use any external pull ups. Note: If you want modem to turn on automatically when power is applied, permanently tie this signal to GND.	0		1.8V	Must be implemented

2.1.2.2 Connectors P4, P1, P2

Connector Designator	Description	Connector Location
P4	Micro SIM Connector	Bottom Side of Module
P1	Primary Antenna Connection	Topside of Module
P2	Secondary Antenna Connection	Topside of Module

2.2 Mechanical Specifications

2.2.1 Mechanical Characteristics

Parameter	Typical	Unit	Note
Dimensions (excluding pin height, for solder to board applications)	1.14" x 1.3" x 0.256	Inches	
Dimensions (including pin height, for board to board connector applications)	1.14" x 1.3" x 0.422	Inches	
Weight	9	Grams	
Connector Insertion/Removal	Hundreds	Cycles	

2.2.2 Mating Connectors

Connector Designator	Manufacture	Populated On Modem	Recommended Mate	Mate Manufacture
J1, J2	3M	951110-2530-ARPR	950510-6102-AR	3M
			Acceptable Alternate NPPN101BFCN-RC	Sullins Connector Solutions
P4	JAE	SF56S006V4B	Micro SIM Card (3FF)	Cellular Carrier
P1, P2	Hirose	U.FL-R-SMT(10)	CAB.011	Taoglas

2.2.3 Device Placement

Make sure the LTE910XF is installed in the correct orientation; failure to do so will damage the device and void the warranty.

2.3 Environmental Specifications

Parameter	Min	Typical	Max	Unit	Note
Operating Temperature	-40	25	+85	°C	
Storage Temperature	-40	25	+85	°C	
Operating Humidity	20		90	%	Non-condensing

3. IMPORTANT DESIGN CONSIDERATIONS

3.1 ON_OFF Signal

To conserve power, the Telit LE910 does not automatically start up when power is applied. The baseboard design must supply a means to assert the ON_OFF signal for the specified time (at least 5 seconds) and then released to start-up the module. After asserting the ON_OFF signal, software must wait for 15 seconds before attempting to communicate with the LE910. To make module automatically start when power is applied, tie ON/OFF signal to GND permanently. See Telit Hardware User Guide for additional details regarding the ON_OFF signal.

3.2 Power Supply Requirements

The equipment must be supplied by an external limited power source in compliance with the clause 2.5 of the standard IEC-60950-1. The module will regularly consume high amounts of current on the Main Power Supply (VCC), up to 2A during active transmits and receives. The baseboard power supply should be designed to support peak currents up to 2 Amps. A 100uF capacitor should be placed near the VCC pin on the module to ensure ample energy is available, with a low inductance path to the VCC pin. For example power supply designs, there are multiple references available. See the Telit Hardware User Guide which has an example of both Linear and Switching regulator designs.

3.3 Serial Communications

The LE910 can communicate over UART and/or USB. Design should implement one or both serial interfaces to be able to send commands to the modem.

3.4 Network Connection Status LED

The ON/nSLEEP signal on pin 13 drives the on-board LED indicating network status. By default, the LTE module has this setting disabled. Use the following commands to enable and save this feature.

First, configure the GPIO for alternate function:

AT#GPIO = 1,0,2

The modem should respond with:

OK

Next, set the desired LED behavior with this command:

AT#SLED=2,10,10

The modem should respond with:

OK

Finally, commit the changes to non-volatile memory so the setting will persist across power down/power up:

AT#SLEDSAV

The modem should respond with:

OK

LED Status	Network Status Indication
Permanently OFF	Device OFF or setting disabled (see above)
Permanently ON	Searching for Network & Not Registered
Slow Blinking	Registered with full service
Permanently ON	Call is active (Modem has been registered)

4. MOUNTING GUIDELINES

The LTE910XF embedded cellular modem supports multiple connection methods, the two primary methods are board to board connectors and soldering directly to the baseboard.

4.1 Board to Board connectors approach

The Standard Industry 20-pin form factor calls for two, 10 pin, 2mm pitch female receptacles.

There are many connector manufacturers that can be used; below is one readily available product:

Manufacturer: 3M

Alternate: Sullins Connector Solutions

Part Number: 950510-6102-AR

Alternate P/N: NPPN101BFCN-RC

Typical part drawing and footprint information:

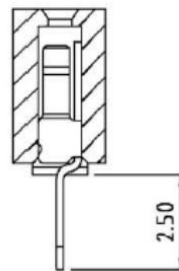
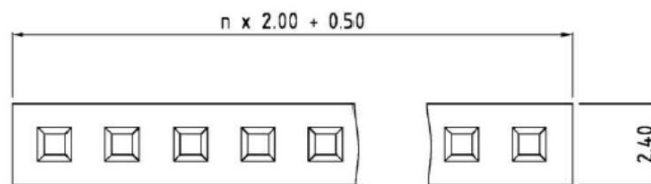
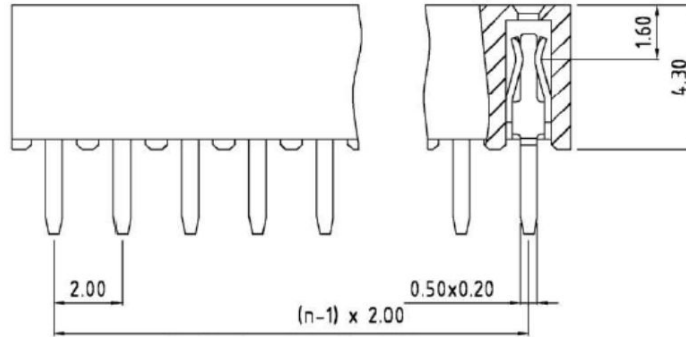

PCB Layout

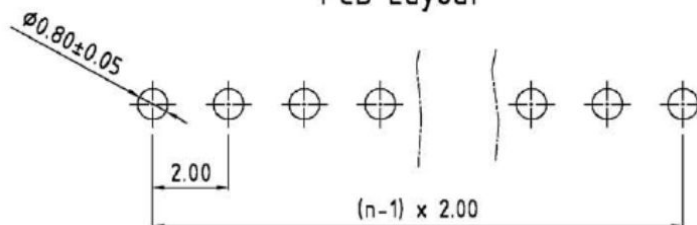

4. MOUNTING GUIDELINES continued

4.2 Solder to Board Connection Approach

The module can be soldered directly to a PCB. The PCB should be designed with two rows of ten, 0.8mm plated thru holes spaced 2mm apart. The two rows should be 22mm apart. See drawing for recommended footprint. Measurements are in millimeters. U.FL locations are marked with circles, P1 and P2 on top side of board, P4 is Micro SIM card connector on bottom side of board.

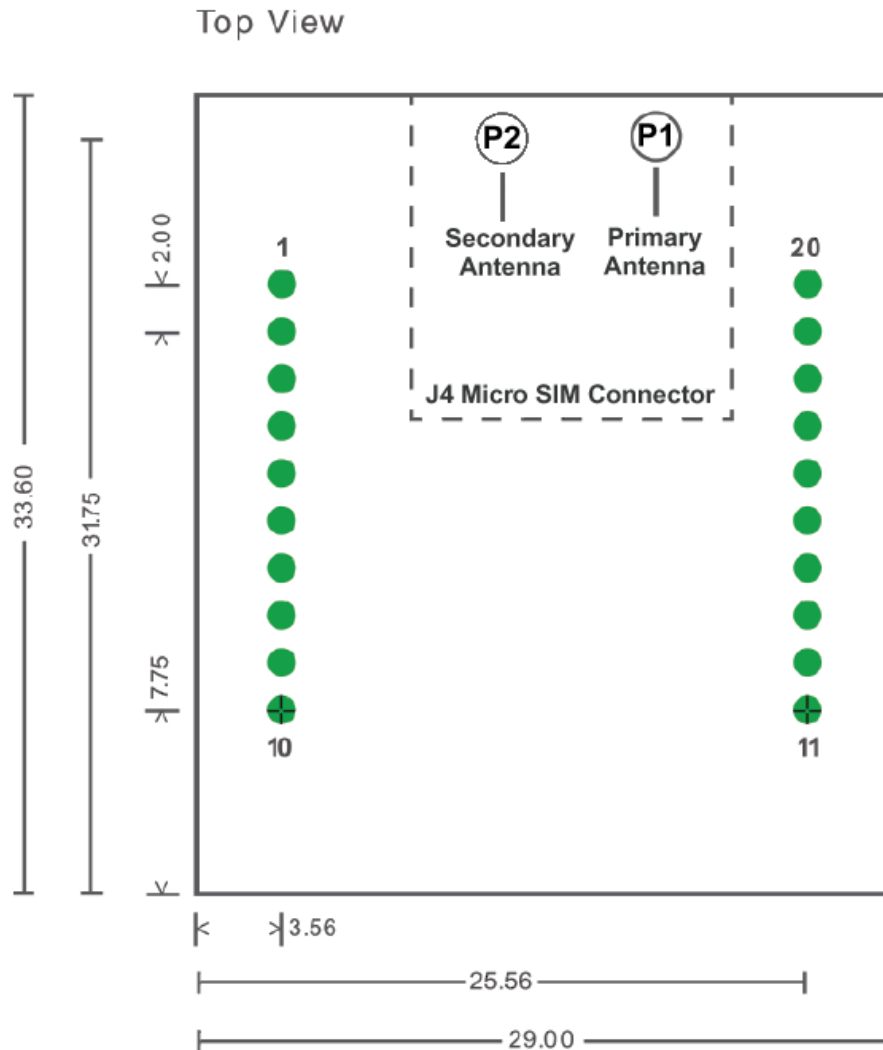

5. ANTENNA CONSIDERATIONS

5.1 Antenna Requirements

These tables are copied from Telit LE910 V2 Hardware User Guide. Designers should review latest LE910 V2 Hardware User Guide to ensure the information is up to date.

Antenna Requirements	
Frequency Range	Depending by frequency band(s) provided by the network operator, the customer shall use the most suitable antenna for that/those band(s).
Bandwidth	140 MHz in LTE/WCDMA Band 2
	445 MHz in LTE Band 4
	70 MHz in LTE/WCDMA Band 5
	47 MHz in LTE Band 12
	41 MHz in LTE Band 13
Impedance	50 ohm
Input Power	>24Bm Average power
VSWR Absolute Maximum	< 10:1 (limit to avoid permanent damage)
VSWR Recommended	< 2:1 (limit to fulfill all regulatory requirements)

5.2 Recommended Antennas

Type	Manufacturer	Part Number
Primary & Secondary	Taoglas ¹	TG.30.8113

Note 1 : U.FL to SMA adapter required.

6. CERTIFICATIONS

6.1 Carrier Specific

Each carrier has different requirements for activating the LE910 modem on their networks. Many accept the Telit PTCRB & GCF certification to allow device on the network, however, recent carrier preferences may require the end product to go through PTCRB & GCF certification in the final enclosure, antenna, and software configuration.

6.2 Geography Specific

Federal Communications Commission (FCC47) part 22, 24
Complies with FCC47 Part 15 Class B Radiated and Conducted Emissions

7. FEDERAL REGULATORY LICENSING

7.1 Export Control Classification Number (ECCN)

ECCNs are five character alpha-numeric designations used on the Commerce Control List (CCL) to identify dual-use items for export control purposes. An ECCN categorizes items based on the nature of the product, i.e. type of commodity, software, or technology and its respective technical parameters.

All LTE910XF Modems: 5A992.a

7.2 Harmonized Tariff Schedule Code

HTS Code: 8517.62.0010

8. END PRODUCT LABELING REQUIREMENTS

Contains FCC ID: RI7LE910NAV2 and IC ID: 5131A-LE910NAV2

This device complies with Part 15 of the FCC Rules. Operation is subject to the following two conditions: (1) This device may not cause harmful interferences, and (2) this device must accept any interference received, including interference that may cause undesired operation.

Cellular LTE910XF v8.00 Plug-In XF Footprint Modem User Manual



Revision History

Revision	Revision Date	Note
00	12/12/17	LTE910XF v8.00 Individual Plug-In User Manual

JANUS REMOTE
C ● M M U N I C A T I O N S ●

Division of The Connor-Winfield Corporation

2359 Diehl Road • Aurora, IL 60502

630.499.2121 • info@janus-rc.com

www.janus-rc.com